



Plan 1 SP8C

1.17 CUBIC FEET ENCLOSURE

Basic Construction Notes:

1. Enclosure inside dimensions compensate for the internal volume taken up by speaker components, internal bracing, and the vent. Slight variations due to the specific mid- and high-frequency components used do not affect performance.
2. All corners and joints to be securely glued and nailed or screwed.
3. Three mutually adjacent inside surfaces (top, one side, and rear) to be lined with a 1- or 2-inch thickness of glass wool or similar acoustic absorptive material. Do not block vent opening.
4. Enclosure material to be 3/4" plywood or particle board.
5. Internal bracing to be 3/4" x 3/4" or 1" x 1" material.
6. For more detailed commentary on construction, see "Electro-Voice Guide to Speaker Enclosure Construction" (Form 1788).

Speaker Installation and Application Notes:

1. Plans show permanently installed front and rear enclosure panels. Mid- and high-frequency components are mounted and wired through the woofer opening. The woofer is installed, last, on the front side of the front panel.
2. Machine screws (bolts) and nuts should be used for installation of speaker components. T-nuts are convenient, since they are easily affixed to the front panel before component installation.
3. The 8HD horn (part of BB4A) must be front mounted so that the driver (1823M) clears the rear enclosure panel. Use # 10-24 or # 10-32 nuts and bolts.
4. The T35 tweeter (part of BB1) must be rear mounted. Use # 8-32 or # 8-40 nuts and bolts.
5. After other system components and wiring are installed, the SP8C should be mounted from the front side of the front panel. Use 1/4-20 T-nuts and bolts. (T-nuts must be used).
6. Due to front panel space limitations, the vent opening has been placed at the rear of the enclosure and must be a minimum of 2-3" away from room surfaces for proper performance.

Performance Specifications with SP8C:

1. Low-Frequency 3-dB-Down Point: 50 Hz
2. SPL_{MF}(max): 107 dB
3. SPL_{LF}(max): 105 dB
4. For definitions and other specifications see Engineering Data Sheet and E-V brochure "How to build an Electro-Voice Component Speaker System. From the ground up."

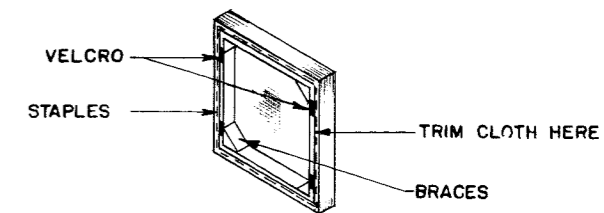
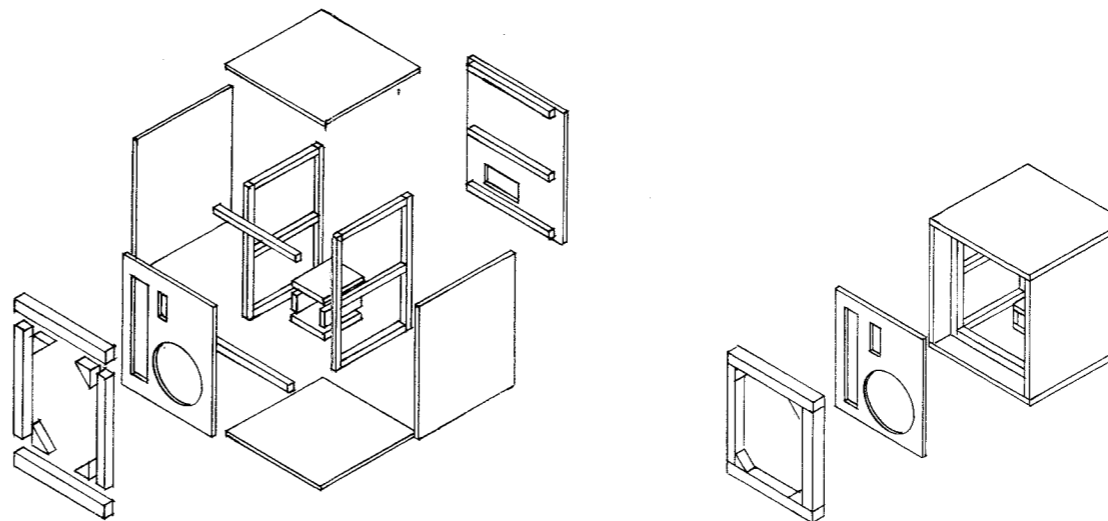

REAR VIEW OF GRILLE FRAME WITH CLOTH

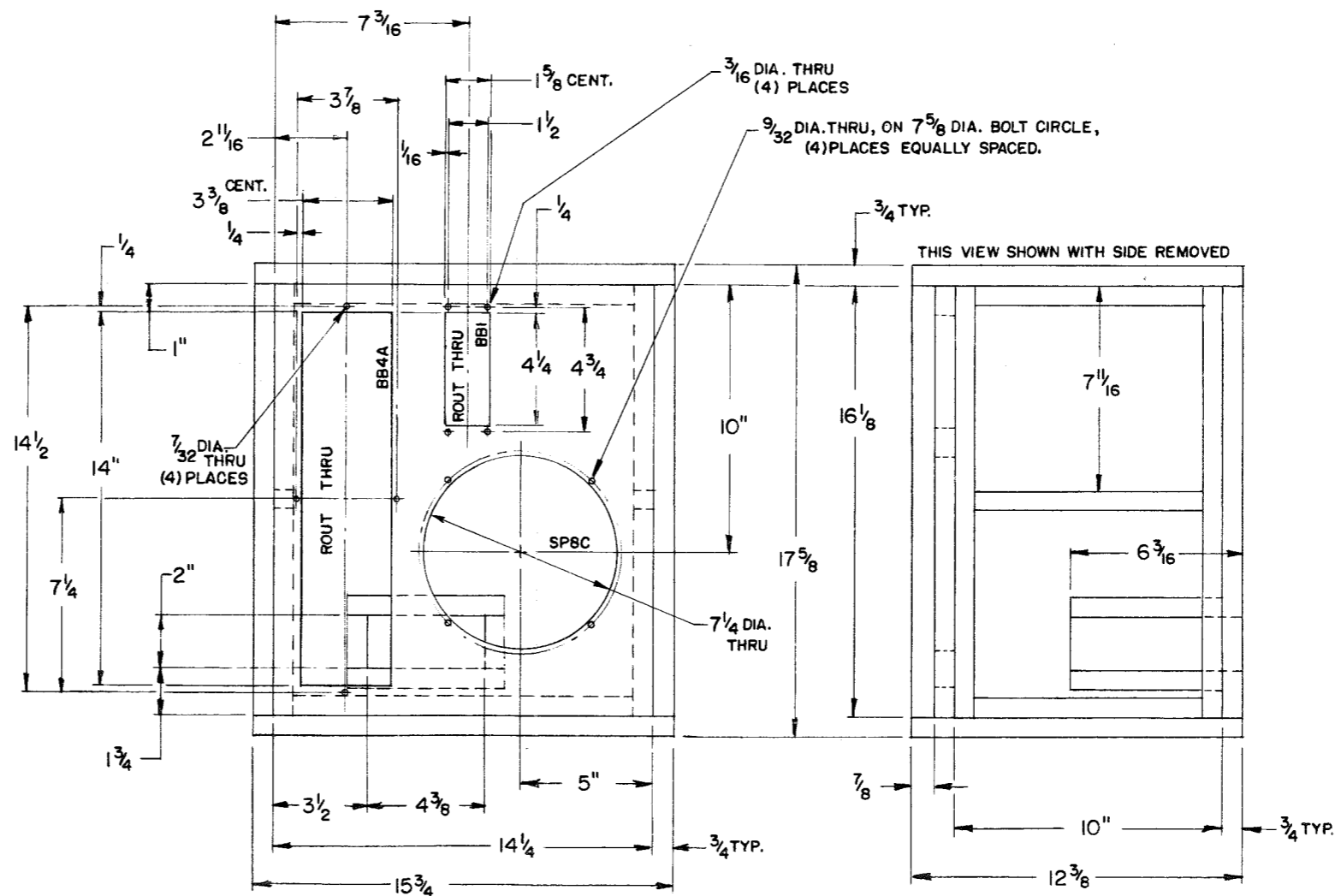

Electro-Voice[®]

a gulton company

600 CECIL STREET, BUCHANAN, MICHIGAN 49107