

DESCRIPTION

The Electro-Voice TL606 low frequency loudspeaker system is a vented-box (bass-reflex) design with gross internal volume of 3.2 cu. ft. The system has been designed for use with the Electro-Voice EVM15L 15 inch loudspeaker. The usable frequency range of the TL606 is roughly 40 to 1300 Hz. The efficiency of the TL606 is 6% (half-space load, 80 to 800 Hz, 8 ohm nominal impedance) and as a result will generate outputs of 6 acoustic watts at the rated input of 100 watts.

The design provides a selection of two different low frequency response curves by the optional use of a removable port cover. In the normal configuration (port cover off) the response is flat down to the lowest possible frequency. In the step-down configuration (port cover on) the response exhibits a sloping gradual low frequency rolloff but with about a one-half octave extension of low end response. The step down mode of operation is intended to be used with simple before-the-power-amp equalization to flatten the response (only 6 dB maximum boost required, equalizer details available on request).

The following table lists the box resonance frequency (f_B), the 3 dB down frequency (f_3) and the usable lower limit frequency (f_{LL}) for both configurations.

FREQUENCY	NORMAL	STEPDOWN
f_B	55 Hz	40 Hz
f_3	63 Hz	78 Hz
f_3 (with EQ)	—	42 Hz
f_{LL}^*	45 Hz	39 Hz

*The system can generate one-half acoustic watt or more down to f_{LL} .

The following graph shows the system's power output low frequency response in both the normal and step-down modes.

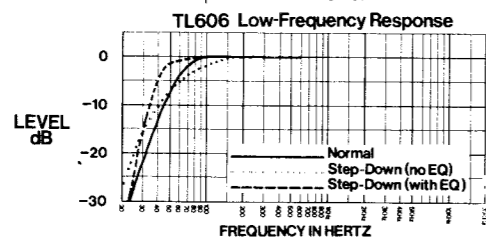

The curve which follows shows the system's low frequency maximum acoustic power output versus frequency. The maximum output is limited by either (1) the thermal power handling capacity of the speaker, or (2) the speaker's maximum linear cone excursion capabilities, whichever occurs first.

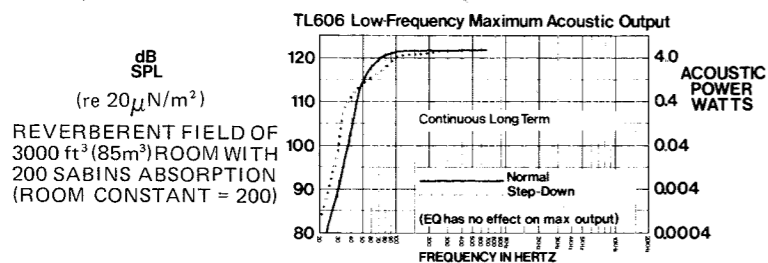

Note that some 2 to 3 dB of maximum output in the 60 to 90 Hz range is sacrificed when the step-down mode is used.

The TL606 input impedance versus frequency is shown in the following graph (normal mode).

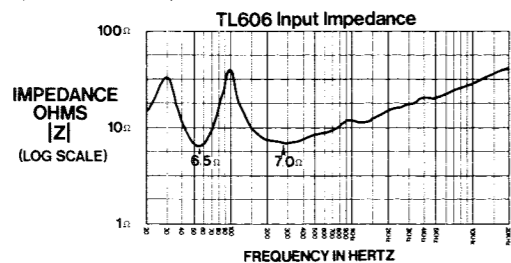

TL606 Builders Plans

EVM15L 3.2 CU. FT. BASS BOX

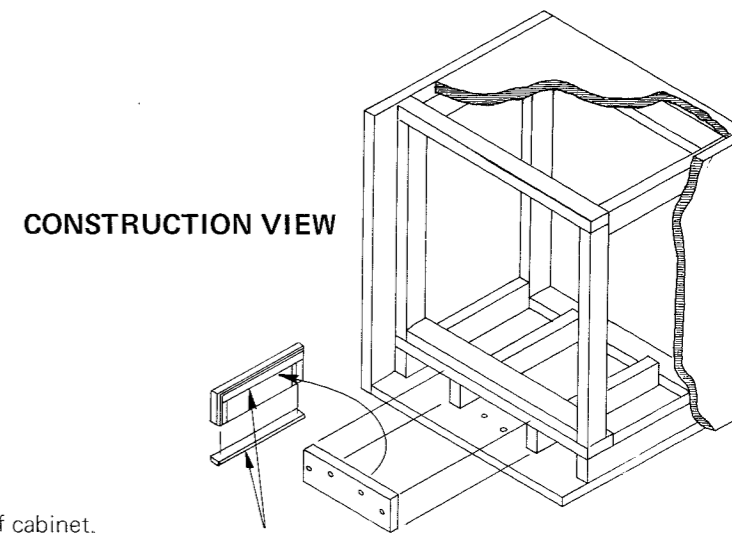
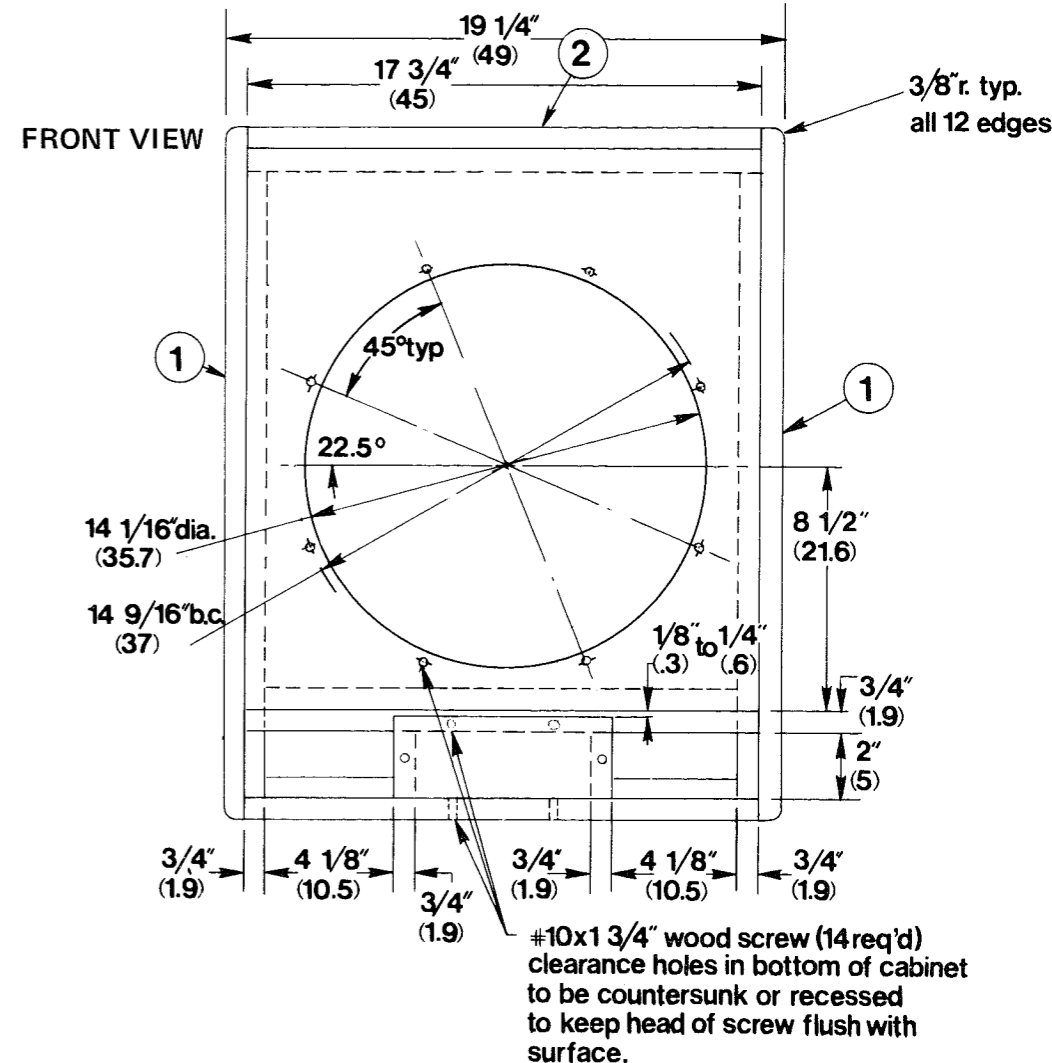
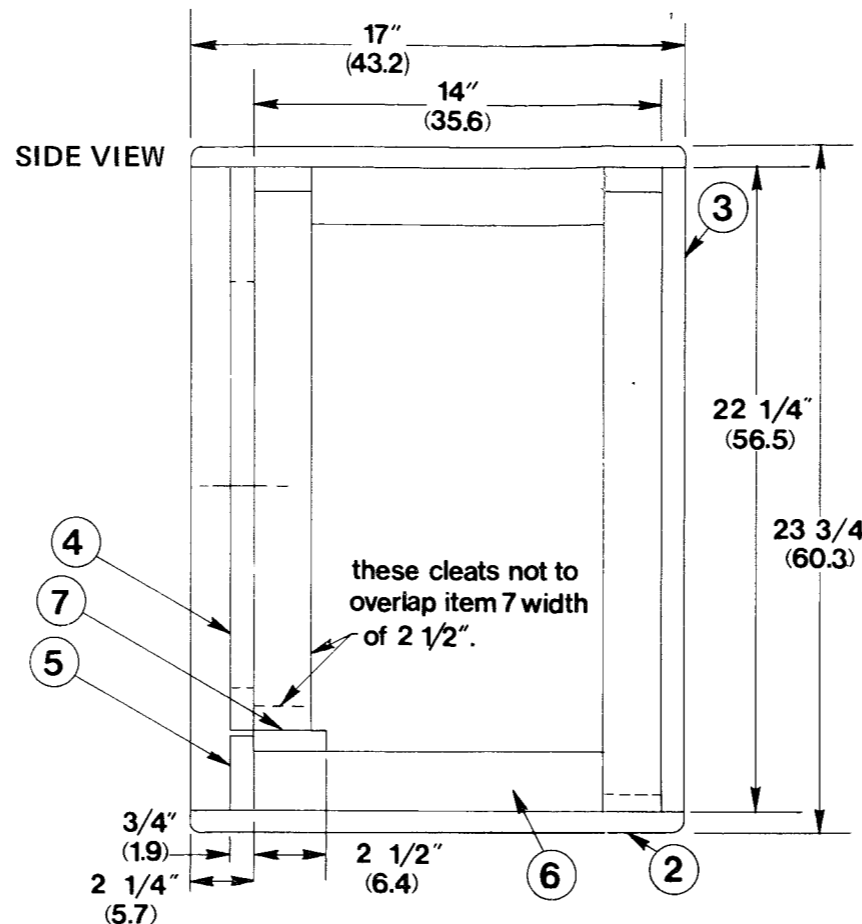

CONSTRUCTION NOTES:

- All joints should be securely glued and nailed (or stapled).
- All joints must be airtight. Seal questionable joints with silicon based caulking compound.
- Use 1/2" wide weather stripping tape around port cover (item 5) for airtight seal.
- Speaker must be mounted from front of cabinet.
- Handles, trunk corners, and furniture glides or casters may be added at builders option.
- Input connector should be selected by builder and mounted on rear.
- Grille not shown.
- Parts listed and dimensioned in chart below must conform to dimensions on drawing for proper cabinet tuning.
- The builder may select material and dimensional fit for parts not listed in chart.
- The cleats (items 6) to be flush with rear of baffle (item 4) and run completely back to rear cleats.
- Line top, both sides, and back with 3" fiberglass insulation. Insulation must not block port opening on inside of cabinet.

PARTS LIST - TL606

ITEM	MATERIAL	SIZE	QTY.	REMARKS
1	3/4" (1.9)	17" (43.2) x 23-3/4" (60.3)	2	Sides
2	Plywood	17-3/4" (45.1) x 17" (43.2)	2	Top and bottom
3	or	17-3/4" (45.1) x 22-1/4" (56.5)	1	Back
4	particle board	17-3/4" (45.1) x 19-1/2" (49.5)	1	Baffle
5		2-9/16" (6.5) x 8" (20.3)	1	Port cover
6	3/4" (1.9) x 2" (5.1) Fir	See Note 10	4	Cleats
7	3/4" (1.9) x 2-1/2" (6.4) Fir	17-3/4" (45.1)	1	Port top

Electro-Voice®
a gulton company
600 CECIL STREET
BUCHANAN, MICHIGAN 49107