

DESCRIPTION

The Electro-Voice TL806Q low frequency loudspeaker system is a vented-box (bass-reflex) design with gross internal volume of 5.2 cu. ft. The system has been designed for use with four of the Electro-Voice EVM-12L 12 inch loudspeakers. The usable frequency range of the TL806Q is roughly 50 to 800 Hz. The efficiency of the TL806Q is 17% (half-spaced load, 100 to 800 Hz, 8 Ohm nominal impedance) and as a result will generate outputs of 68 acoustic watts at the rated input of 400 watts.

The design provides a selection of two different low frequency response curves by the optional use of a removable port cover. In the normal configuration (port cover off) the response is flat down to the lowest possible frequency. In the step-down configuration (port cover on) the response exhibits a sloping gradual low frequency rolloff but with about a one-half octave extension of low end response. The step-down mode of operation is intended to be used with simple before-the-power-amp equalization to flatten the response (only 6 dB maximum boost required). For equalizer details request a copy of E-V Pro Sound Facts No. 1.

The following table lists the box resonance frequency (f_B), the 3 dB down frequency (f_3) and the usable lower limit frequency (f_{LL}) for both configurations.

FREQUENCY	NORMAL	STEPDOWN
f_B	75 Hz	53 Hz
f_3	80 Hz	125 Hz
f_3 (with EQ)	—	56 Hz
f_{LL}^*	60 Hz	50 Hz

*The system can generate 8 acoustic watts or more down to f_{LL} .

The following graph shows the system's power output low frequency response in both the normal and step-down modes.

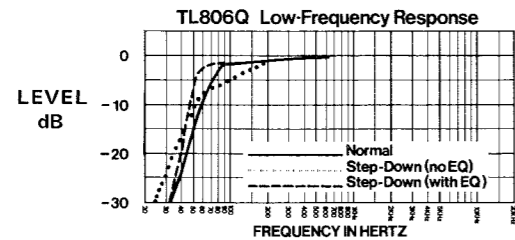

The curve which follows shows the system's low frequency maximum acoustic power output versus frequency. The maximum output is limited by either (1) the thermal power handling capacity of the speaker, or (2) the speaker's maximum linear cone excursion capabilities, whichever occurs first.

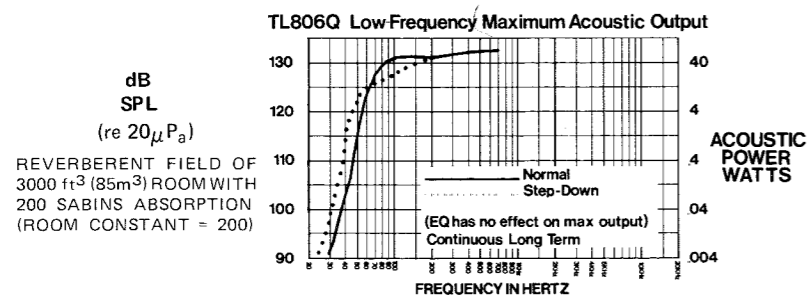

Note that some 2 to 3 dB of maximum output in the 80 to 130 Hz range is sacrificed when the step-down mode is used.

The TL806Q input impedance versus frequency is shown in the following graph (normal mode).

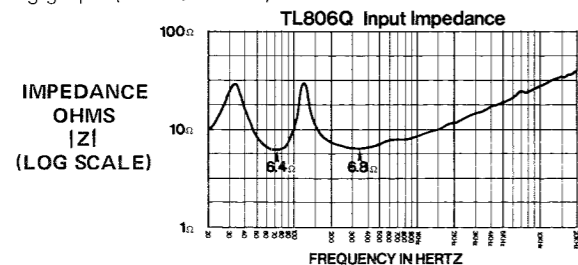

TL806Q

BUILDERS PLANS

(4) EVM-12L,
5.2 cu ft BASS BOX

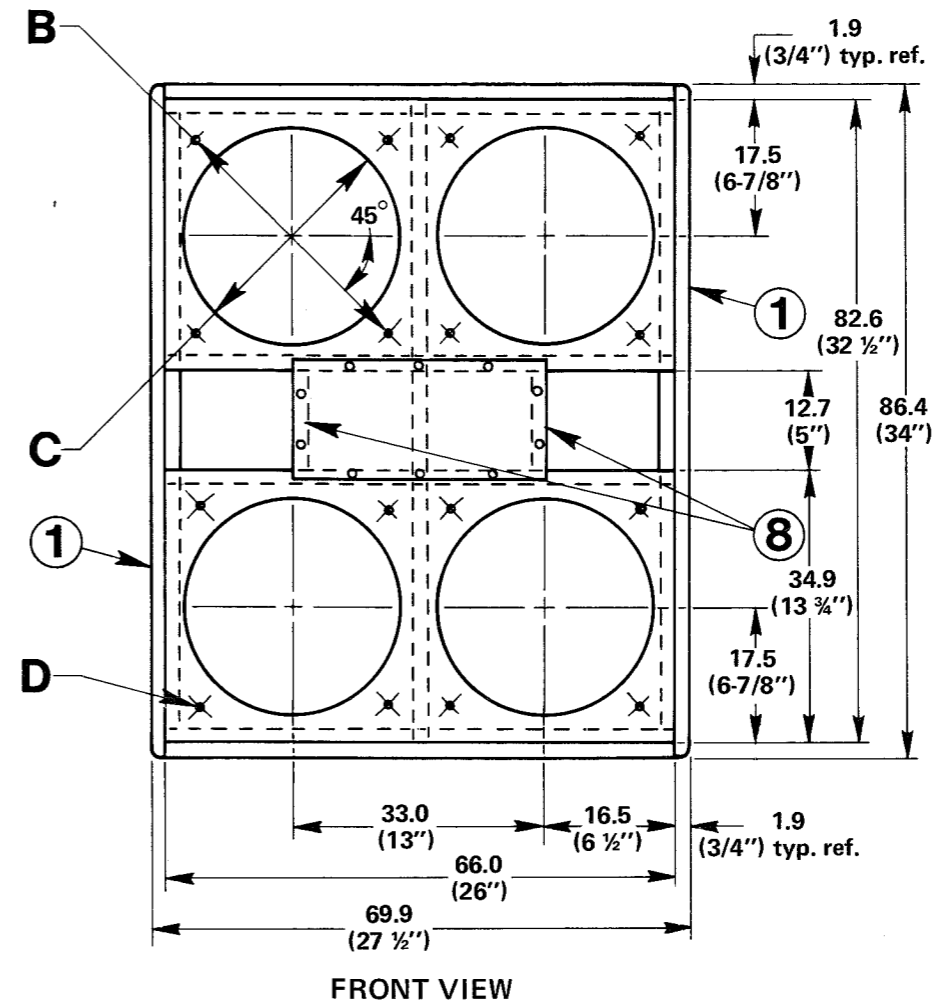
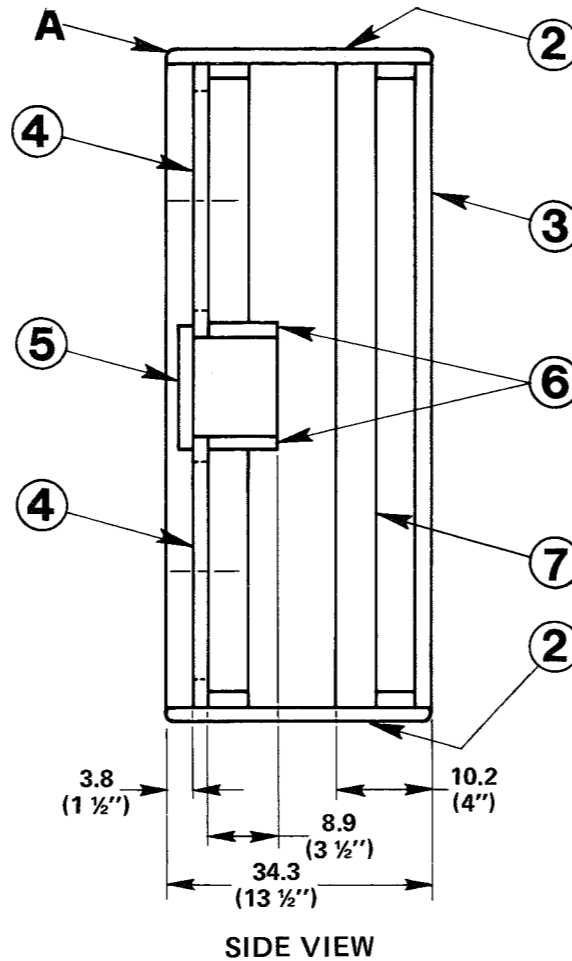
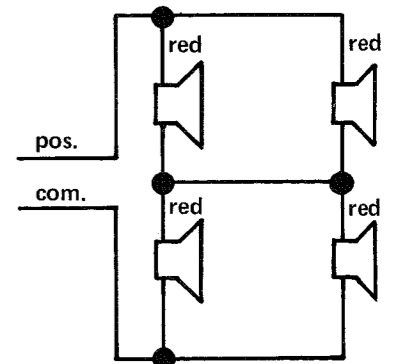

ILLUSTRATION NOTES:

- A 1.0 R (3/8") on all 12 edges
- B 34.8 (13-11/16") B.C. Typ. 4 places
- C 28.1 (11-1/16") dia. thru Typ. 4 places
- D #1/4-20 Long prong tee nut, inserted from back side, (16 places) equally spaced



CONSTRUCTION NOTES:

1. All joints should be securely glued and nailed (or stapled).
2. All joints must be airtight. Seal questionable joints with silicon based caulking compound.
3. Use 1/2" wide weather stripping tape around port cover (item 5) for airtight seal.
4. Speaker must be mounted from front of cabinet. Each speaker may be secured by using the Electro-Voice SMH-1 mounting kit or 8 each 10-32 x 1 1/2" bolts and teenuts on 11-9/16 inch B.C.
5. Handles, trunk corners, and furniture glides or casters may be added at builders option.
6. Input connector should be selected by builder and mounted on rear.
7. Grille not shown.
8. Parts listed and dimensioned in chart below must conform to dimensions on drawing for proper cabinet tuning.
9. The builder may select material and dimensional fit for parts not listed in chart.
10. Line top, bottom, both sides, and back with 3" fiberglass insulation. Insulation must not block port opening on inside of cabinet.

PARTS LIST—TL806Q

ITEM	MATERIAL	SIZE	QTY.	REMARKS
1		34.3 (13-1/2") x 86.4 (34")	2	Sides
2	3/4" (1.9)	34.3 (13-1/2") x 66.0 (26")	2	Top and bottom
3	PLYWOOD	66.0 (26") x 82.6 (32-1/2")	1	Back
4	OR	34.9 (13-3/4") x 66.0 (26")	2	Speaker mounting board
5		15.9 (6-1/4") x 33.0 (13")	1	Port cover
6	PARTICLE BOARD	8.9 (3-1/2") x 66.0 (26")	2	Port top and bottom
7		10.2 (4") x 82.6 (32-1/2")	1	Back panel cleat
8	1.9 (3/4") x 10.8 (4-1/4") Fir	12.7 (5")	2	Port divider

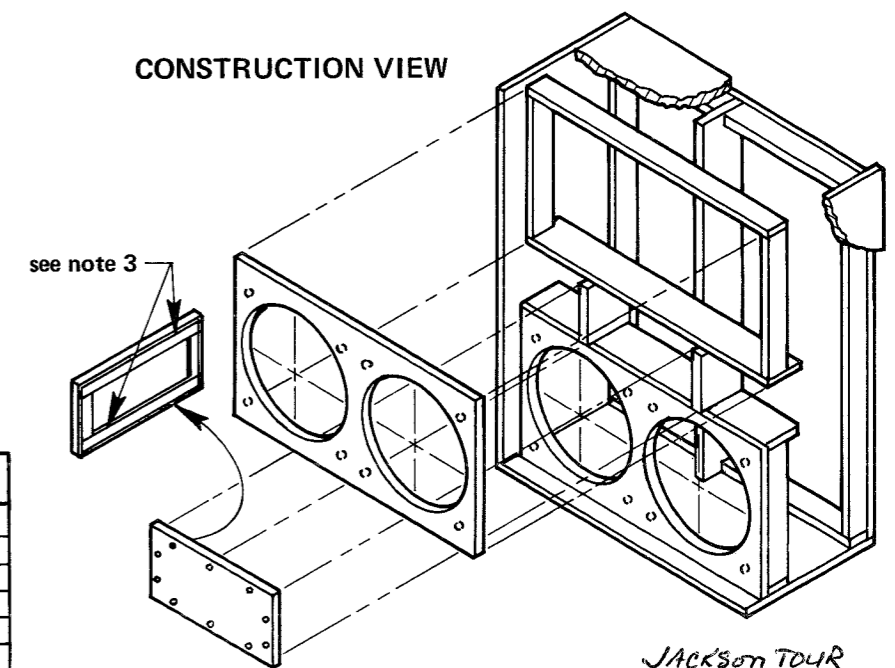

All Dimensions shown in centimeters and (inches).